

How much lumber in that tree?

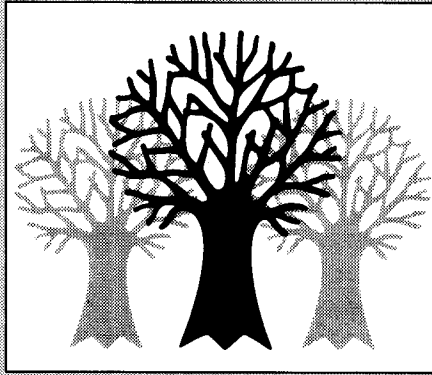

Extension Bulletin E-2915
Rev. April 2004
(Formerly E-461)

MICHIGAN STATE
UNIVERSITY
EXTENSION

Georgia Peterson, Michigan Department of Natural Resources, Extension Natural Resources Agent

There are times when a woodland owner may want to determine the board foot volume of certain trees in his or her woodlot for building purposes or for sale. Measuring the volumes of standing trees enables the property owner to select the proper combination of available trees to provide the desired amount of lumber. Volume calculations can also help the woodland owner avoid harvesting more trees than necessary and can give him or her an accurate accounting of the number of board feet for sale.

Large trees that will yield boards for lumber are called sawtimber trees. Sawtimber is measured and sold in terms of board feet. A board foot is 1 inch thick, 1 foot wide and 1 foot long. The first step in determining the board foot contents of standing trees is measuring their diameters and usable heights. Tables 2, 3 and 4 summarize these volumes using various log rule techniques.

Anyone can determine the board foot content of their trees by following a few simple steps. This bulletin describes how to estimate the amount of lumber in a tree with easy-to-make tools. If an estimate of the entire woodlot is needed, however, the owner should contact an area forester or a consulting forester for this service. More complex techniques are involved in estimating volumes on a large scale, which are beyond the scope of untrained individuals.

Measuring Diameter

Tree diameters are measured at breast height, which is $4\frac{1}{2}$ feet above the average ground level. Although diameter tapes are often used to take this measurement, another tool, called a Biltmore stick¹, is easy to construct in the home workshop. Use a straight piece of hardwood that is free from knots or other defects, as shown in Fig. 1. The stick should be 30 inches long, $\frac{1}{2}$ inch thick and $1\frac{1}{2}$ inches wide, and beveled on one edge.

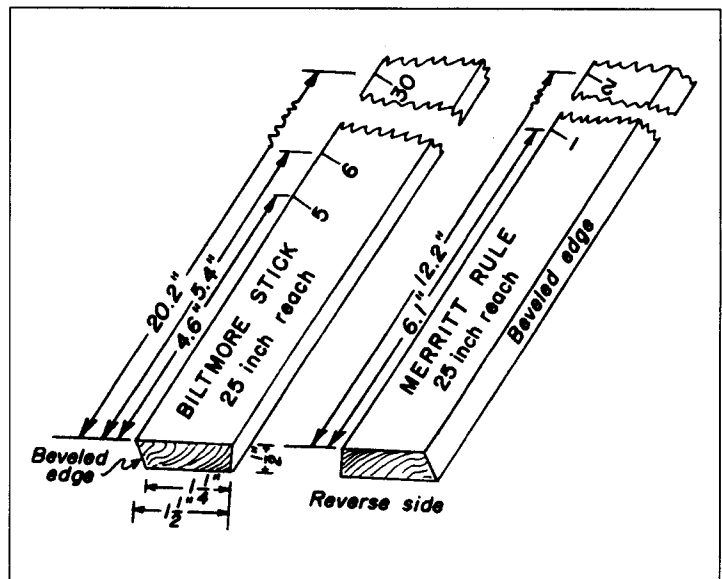

Fig. 1. Dimensions of Biltmore stick designed to measure tree diameter on one side and merchantable tree height on the other side.

Sand the sides and edges of the stick smooth. The stick is then graduated on the unbeveled side according to the figures given in Table 1.

¹The Biltmore stick may also be purchased from forestry equipment catalogues such as Forestry Suppliers or Ben Meadows.

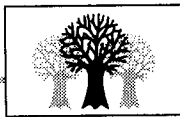

Table 1. Biltmore rule graduations.

Diameter-graduations on stick	Distance in inches from end of stick to diameter graduations	Diameter-graduations on stick	Distance in inches from end of stick to diameter graduations
5	4.6	18	13.7
6	5.4	19	14.3
7	6.2	20	14.9
8	7.0	21	15.5
9	7.7	22	16.0
10	8.4	23	16.6
11	9.2	24	17.1
12	9.8	25	17.7
13	10.5	26	18.2
14	11.2	27	18.7
15	11.8	28	19.2
16	12.5	29	19.7
17	13.1	30	20.2

Measure tree diameters with the Biltmore stick in the following way (see Fig. 2):

1. Hold the stick 25 inches from your eyes in a horizontal position. Hold the beveled edge of the stick against the trunk of the tree at breast height.
2. Look straight at the tree without moving your head from side to side. Adjust the stick so that the left or zero end is lined up with the left side of the tree.
3. Without moving your head, shift the line of sight to the right-hand side of the trunk.

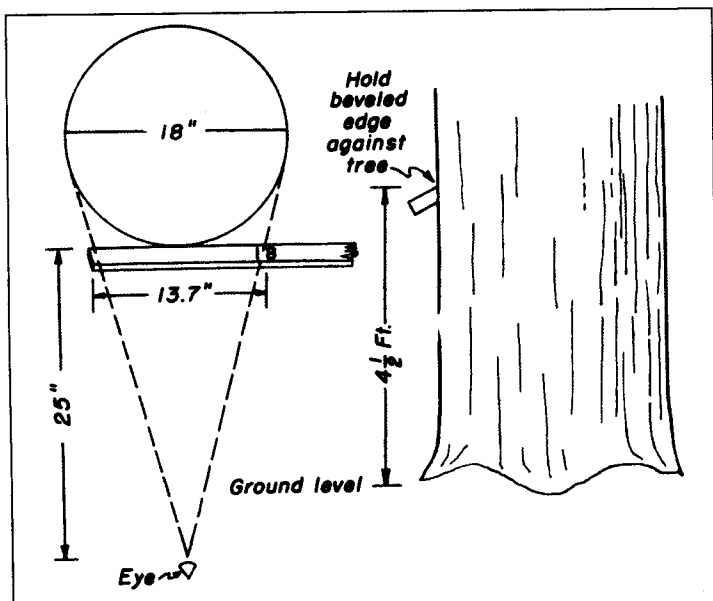

Fig. 2. Measuring tree diameter with a Biltmore stick.

4. Read the diameter on the stick nearest the point at which the line of sight crosses it.

Tree diameter can also be measured using an ordinary tape measure. Wrap the tape around the circumference of the tree at 4.5 feet above its base. Divide the circumference by 3.14 (π) to calculate the diameter of the tree.

Measuring Height

Tree heights are measured in units of 16-foot logs or fractions thereof. In slender, straight trees, this measurement is taken to a point on the upper trunk of the tree where the diameter inside the bark is 8 inches. With older trees, however, excessive branching or forks may reduce the usable height. One should then measure the distance between stump height and usable height.

A Merritt rule for measuring tree heights can be inscribed on the reverse side of the Biltmore stick; then both rules, one for measuring tree diameter and the other for measuring tree height, will be on the same stick.

To inscribe the Merritt rule on the stick, simply mark graduations of 6.1 inches from the zero end of the stick (see Fig. 1). Each graduation represents a 16-foot log length. Inscribe half-log marks halfway between the 16-foot log marks. Make the graduation for both the diameter scale and the height scale with a sharp pencil or marker. Then give the stick a coat of clear var-



nish or polyurethane. This will bring out the color of the indelible lead, as well as protect the stick from moisture and discoloration.

Measure tree heights with the Merritt rule by the following method (see Fig. 3):

1. Stand 66 feet from the base of the tree. Hold the stick vertically at a distance of 25 inches from your eye.
2. Adjust the stick so that the zero end is in the line of sight with the upper limit of usable height.
3. Without moving your head or the stick, shift your line of sight to the stump height at the base of the tree (usually 12 to 16 inches above ground level). From the scale, read the number of logs (or fractions of logs) in the tree.

If the ground is not level, stand on a spot that has about the same elevation as the base of the tree.

Determining Tree Volume

After the diameters and heights of the trees have been measured, the board foot content for each tree can be read from a volume table. Board foot volume is estimated in many ways. Because many of these calculations were developed before the benefit of calculators, estimations are simplified formulas that are easy to tabulate by hand. Other, later formulas are more complex but ultimately more accurate in estimating the amount of useable wood. The International log rule (Table 2), one of these more recent estimation systems, gives a very accurate measure of the amount of lumber that a sound, straight tree will yield at the sawmill.

Local customs, however, sometimes require using other log rule calculations when standing timber is sold. Estimated volumes from two other log rules, Doyle and Scribner Decimal C, are given in Tables 3 and 4.

If you are going to fell the trees yourself and haul the logs to the mill, read the board foot values in Table 2, the International rule. However, if you are selling standing trees in the Lower Peninsula (and if the buyer insists), use the values in Table 3. If your trees are in the Upper Peninsula and the buyer demands it, use the values based on the Scribner Decimal C rule (Table 4).

In using these tree volume tables, increase the volumes by 10 percent for the following trees: balsam fir, spruce, white oak, yellow poplar, black cherry, beech and ash. Also, make suitable deductions for visible defects, such as rot.

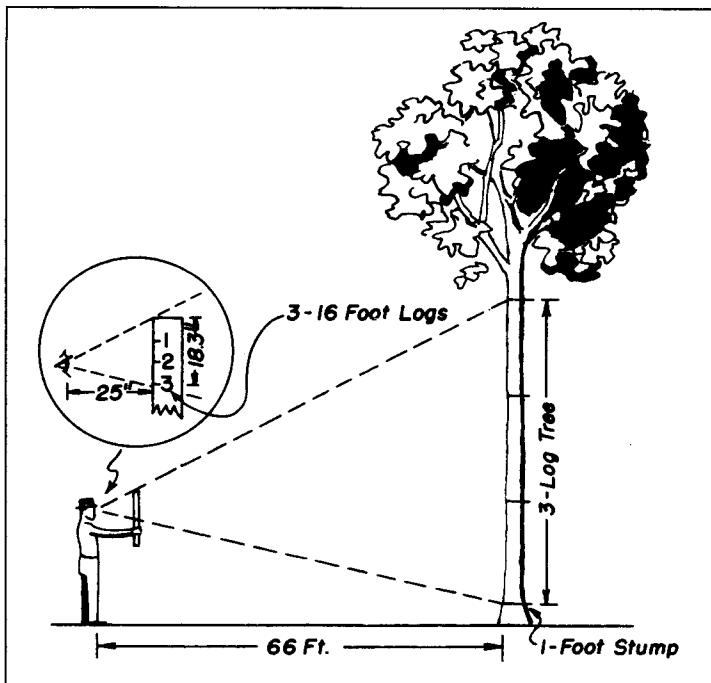

Fig. 3. Measuring tree height in 16-foot log units with a Merritt rule.



Table 2.
Tree volume table
based on International log rule.

Diameter 4½ feet above ground (inches)	Number of 16-foot logs Volume in board feet			
	1	2	3	4
10	35	60		
11	45	75		
12	55	90	120	
13	65	110	145	
14	80	130	175	
15	90	155	200	
16		180	240	285
17		205	280	330
18		235	315	375
19		265	360	425
20		295	400	480
21		330	450	540
22		370	500	605
23		405	550	665
24		440	605	725
25		485	665	800
26			725	880
27			790	950
28			850	1,030
29			920	1,110
30			990	1,200

Table 3.
Tree volume table based on
Doyle rule.

Diameter 4½ feet above ground (inches)	Number of 16-foot logs Volume in board feet			
	1	2	3	4
10	15	20		
11	20	30		
12	30	45	50	
13	40	60	70	
14	50	75	95	
15	60	95	120	
16		115	150	170
17		140	180	210
18		165	215	250
19		195	255	300
20		225	295	350
21		260	345	400
22		295	390	460
23		330	445	520
24		370	495	580
25		415	560	660
26			620	740
27			685	815
28			750	890
29			825	980
30			900	1,070

Table 4.
Tree volume table based on
Scribner Decimal C rule.*

Diameter 4½ feet above ground (inches)	Number of 16-foot logs Volume in board feet			
	1	2	3	4
10	3	4		
11	4	6		
12	5	8	10	
13	6	9	12	
14	7	11	15	
15	8	14	18	
16		16	21	25
17		18	25	29
18		21	28	33
19		24	32	38
20		27	36	43
21		30	41	49
22		34	46	55
23		37	51	61
24		41	56	66
25		45	62	74
26			68	81
27			74	89
28			80	96
29			86	104
30			93	112

*The figures shown in this table must be multiplied by 10 to obtain board foot values.