

SP1



MJ Spli++er™

Single MJ Splitter Installation Manual - 1Si

Micro Jig, Inc.
PO Box 195607
Winter Springs, FL 32719, USA.

Tel: 1-407-696-6695
Web site: www.microjig.com
Email: sales@microjig.com

Copyright © 2004 Micro Jig, Inc.

Low Profile *Dual Function* Splitter

• *Mini Feather Board Effect* • *Kerf Keeper*

Installation Manual—1Si (V2.4) 0705

- for installation of a Single 1/8" or Thin Kerf MJ Splitter Insert -

For Installation on Zero Clearance Insert with no existing splitter opening ONLY!
For making 90° cuts ONLY – MJ Splitter will NOT accommodate cuts with a tilted arbor!
Standard 1/8" Kerf and Thin Kerf models are available separately!

Made in USA - Patent Pending

Model # SP-0125 (Green)

For full 1/8" standard Kerf 10" saw blade
Green MJ Splitter thickness : 0.118" (± 0.001")
Kerf Range 0.118" - 0.145" (3 - 3.2mm)
Package contents

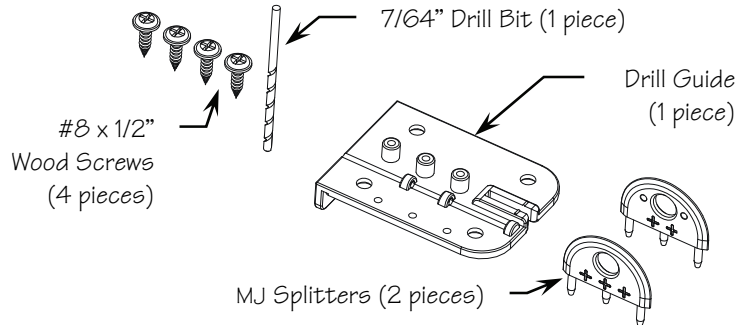

Model # SP-0100TK (Yellow)

For 10" Thin Kerf saw blade
Yellow MJ Splitter thickness : 0.086" (± 0.001")
Kerf Range 0.090" - 0.118" (2.29 - 3mm)
Package contents

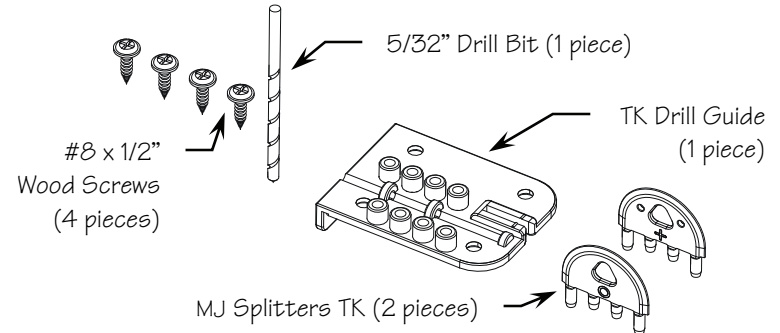

Preparation - For best results, we suggest that you read this Installation Manual thoroughly before you start.

- Rip fence must be parallel to the saw blade if the MJ Splitter is used with the GRR-Ripper® System.
- Zero Clearance Insert (ZCI) must be leveled with the table saw top.
- To achieve a "feather board" effect, the ZCI must fit snugly in the opening and **ALL** installation steps must be followed closely.
- A kerf in the ZCI must be created at 90° with the saw blade (without stiffener) raised to its **highest** setting for maximum cutting depth, this will allow cuts with the saw blade to be raised at any height.

Note: ZCI used should be made of sturdy material, as any deflection on the ZCI when downward pressure is applied may cause the work piece to be pulled away from the fence, resulting in a cut that is not parallel to the fence.

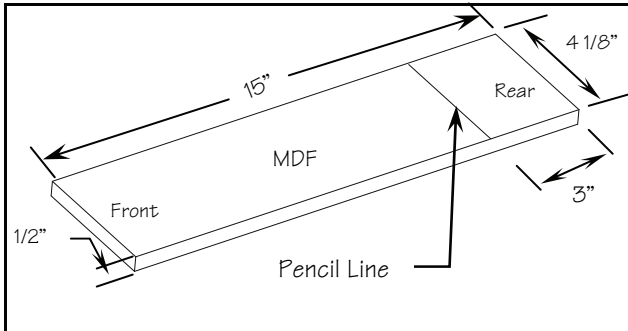

WARNING: MAKE SURE THAT YOU HAVE THE CORRECT MODEL OF MJ SPLITTER FOR YOUR SAW BLADE PRIOR TO INSTALLATION. MISTAKENLY USING A THIN KERF SAW BLADE WITH A 1/8" SPLITTER WILL CAUSE BINDING AND DAMAGING THE 1/8" SPLITTER. MINIMUM 2" OF SPACE IS REQUIRED BEHIND A FULLY RAISED 10" SAW BLADE FOR INSTALLATION OF A SINGLE MJ SPLITTER.

Installation Procedure

These procedures are for use with a standard 10" diameter with either 1/8" kerf or Thin Kerf saw blade depends on the model you purchased. Please follow the exact order of steps and sequences.

Step 1 (for both 1/8" and Thin Kerf models) - Prepare a Setup Board

Prepare a Setup Board from a 1/2" thick man-made sheet stock (preferably 1/2" MDF) - 15" L x 4-1/8" W. The front edge must be 90° to the long edges. Draw a pencil line across the width that is 3" from the rear end.

Note: Better grade 1/2" plywood with no void can also be used - it must be flat and dimensionally stable.

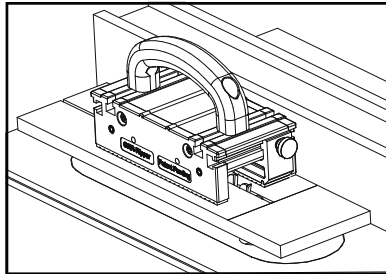

Step 2 (for both models) - Create a Saw Kerf on the Setup Board

1) Set the saw blade at 1/4" above the top surface of the setup board. Be sure the table saw top is clean and free from sawdust and other debris.

2) Secure the rip fence at 2" to the right of and parallel to the saw blade.

IMPORTANT: Keep the rip fence locked in position until the installation is complete.

The saw kerf that you are going to create in the next step will be the alignment path for the Drill Guide. It is extremely important that the saw kerf is parallel to the right edge of the Setup Board. Using the GRR-Ripper® for this ripping procedure is the best way to ensure a parallel cut.

3) Feed the Setup Board through the saw blade and stop at the pencil line.

4) Turn off the saw motor while maintaining firm pressure on the GRR-Ripper®, and wait until the saw blade comes to a complete stop.

Model SP-0125
1/8" Kerf Splitter - Green
 Follow drawings under here ↓

Remaining installation steps are similar for both models of the MJ Splitter - slight differences can easily be observed in their drawings with annotations.

Model SP-0100TK
Thin Kerf Splitter - Yellow
 Follow drawings under here ↓

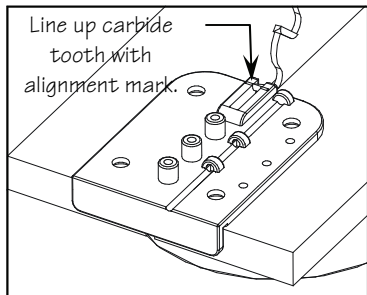

Step 3 - Establish the Guide Hole Distance from the Saw Blade

1) Disconnect the power to the table saw.

2) Pull back the Setup Board so the saw blade (without stiffener) can be raised to its **maximum** height within the saw kerf.

3) Place the bottom center rib of the Drill Guide into the saw kerf and push the Drill Guide toward the saw blade until its cheek comes in contact with the front edge of the Setup Board, and one of the carbide teeth becomes engaged in the front opening of the Drill Guide. Align that tooth with the alignment mark on the Drill Guide's opening. Make sure that all guide holes are still within the ZCI. This will establish the distance of the guide holes behind the saw blade when it is fully raised.

Note: The Drill Guide's opening may be wider than your saw blade, this is normal. MJ Splitter is not designed to align to the center behind the saw blade.

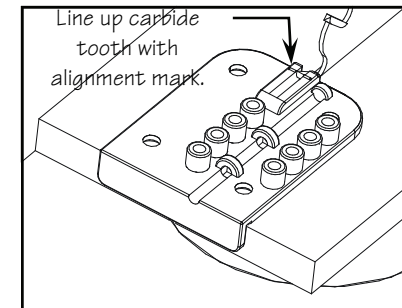

Model SP-0125
1/8" Kerf Splitter - Green
 Follow drawings under here ↓

MJ Spli++er™

Model SP-0100TK
Thin Kerf Splitter - Yellow
 Follow drawings under here ↓

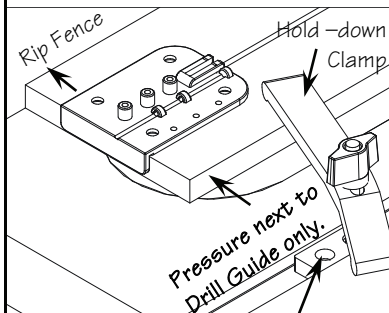

Micro Jig ZeroPlay™
 Guide Bar Stop

Step 4 - Securing the Setup Board

- 1) Lower the saw blade just below the Setup Board top surface without altering the position of the Setup Board and the Drill Guide.
- 2) Clamp the Setup Board in position while applying firm finger or light feather board pressure on the Setup Board against the fence so that the Drill Guide is tight in the saw kerf. This ensures that the right edge of the bottom rib on the Drill Guide is in full contact with the right edge of the saw kerf. This will also align the centers of the guide holes at the pre-determined distance from and parallel to the right edge of the saw kerf, regardless of the actual width of the saw kerf. (Vibration will inevitably cause the saw kerf to be slightly wider than the width of your saw blade.)

Note: The illustration shows a fast and simple way of clamping the Setup Board by using a Hold-Down Clamp and the Stop from Micro Jig's ZeroPlay™ Guide Bar System. You may also clamp a board bridged over the Setup Board from the edge of your table saw top.

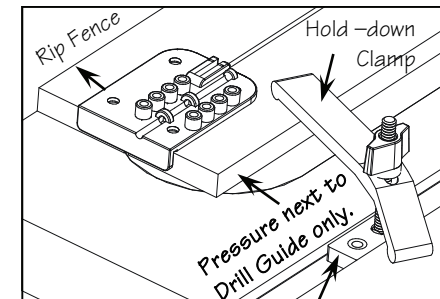

Micro Jig ZeroPlay™
 Guide Bar Stop

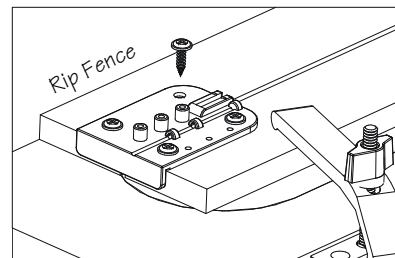

Step 5 - Securing the Drill Guide

- 1) Secure the Drill Guide onto the Setup Board using (4) #8 x 1/2" wood screws (provided). Pilot holes are not required if you use a power hand drill (the bottom of the screw holes are countersunk to accommodate any swarf from the drilling operation). DO NOT drive the screws all the way with the power drill to prevent stripping the threads - lightly tighten the screws with a Robertson or Phillips screwdriver.
- 2) If you prefer pilot holes, use a 1/8" drill bit to drill the pilot holes NOT MORE than 1/8" deep, and lightly tighten the screws by hand.

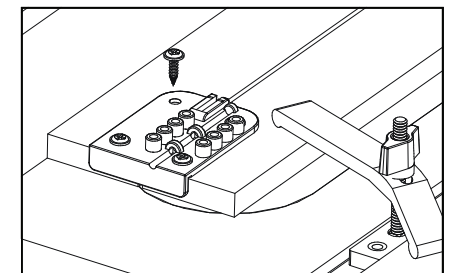

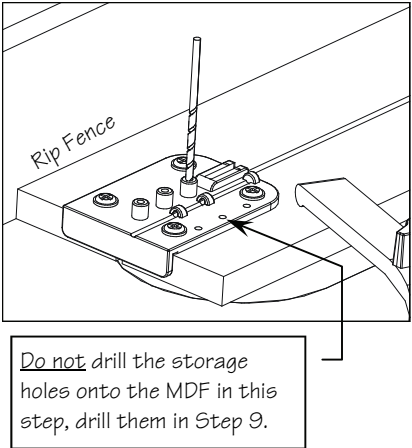
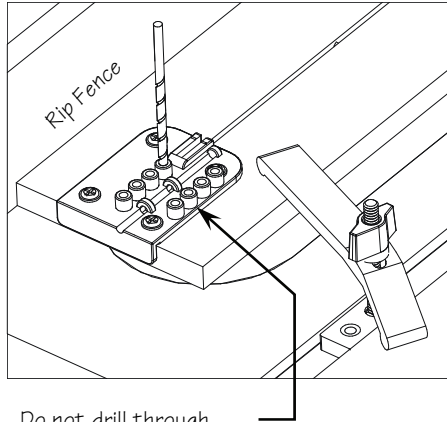
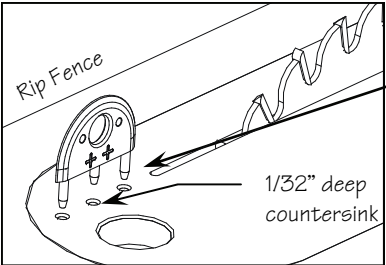
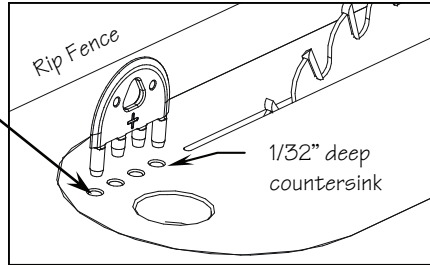
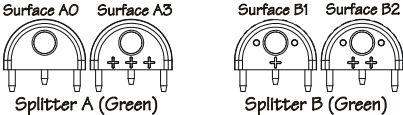
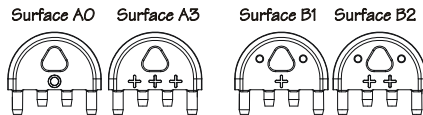
<p>Model SP-0125 1/8" Kerf Splitter - Green Follow drawings under here ↓</p>	<p>MJ Spli++er™</p>	<p>Model SP-0100TK Thin Kerf Splitter - Yellow Follow drawings under here ↓</p>
	<p>Step 6 - Drilling the Splitter Location Holes</p> <p>1) Make sure the Drill Guide is secured on the Setup Board and that there is no debris or gap between them. The guide holes must be perpendicular to the Setup Board. Now, lower the saw blade completely to avoid drill bit contact.</p> <p>2) Chuck the provided drill bit into a power hand drill and carefully line up the drill with one of the guide holes. Hold the hand drill as perpendicular and steady as possible and drill through the guide hole to make that MJ Splitter location hole on the ZCI.</p> <p>IMPORTANT: Drill each hole in one single quick and continuous motion. DO NOT stop and go or re-drill the same hole, as this will enlarge the MJ Splitter location hole and the guide hole, thus resulting in a loosely fitting MJ Splitter.</p> <p>3) Drill the remaining holes in the same manner.</p> <p>Note: The pins on the MJ Splitters are 3/8" in length. Preferably, drill through holes on the ZCI. If your ZCI uses replaceable blanks thinner than 3/8" and has a metal frame under the required hole locations, the pins of the MJ Splitters need to be shortened accordingly. If your ZCI is made out of hard plastic or other material that does not "give," e.g., phenolic or solid surface material, you may need to ream the location holes lightly with the same provided drill bit.</p> <p>4) Countersink the mounting holes on the ZCI about 1/32" deep, this provides relief for the radius edges on the pins.</p>	
	<p>Step 7</p> <p>Push the MJ Splitter completely down - by hand only - so that it fits tightly in the holes. Dip the pins in wax if the fit is very tight.</p>	
 <p>Surface A0 Surface A3 Surface B1 Surface B2</p> <p>Splitter A (Green) Splitter B (Green)</p> <p>Use an ultra fine point marker to highlight all the "+" signs for easy identification.</p>	<p>Step 7A - Each surface of the two MJ Splitters, A & B, extends a different distance from the center of the pins. In use, each additional "+" sign indicates that surface is 0.003" (SP-0125) or 0.002" (SP-0100TK) ± closer to the fence than the surface that has one less "+" sign. This option also allows you to select a surface that protrudes slightly into the left edge of the keeper piece by thousandths of an inch, which generates slight tension - like a mini feather board - behind the saw blade.</p> <p>Test both surfaces of each MJ Splitter facing the rip fence and select the surface that best suits your preference. When cutting material other than wood, such as aluminum or plastic, use the surface that provides no tension against the material.</p>	 <p>Surface A0 Surface A3 Surface B1 Surface B2</p> <p>Splitter A (Yellow) Splitter B (Yellow)</p> <p>Use an ultra fine point marker to highlight all the "+" signs for easy identification.</p>

Model SP-0125
1/8" Kerf Splitter - Green
 Follow drawings under here ↓

MJ Spli++er™

Model SP-0100TK
Thin Kerf Splitter - Yellow
 Follow drawings under here ↓

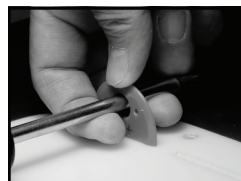
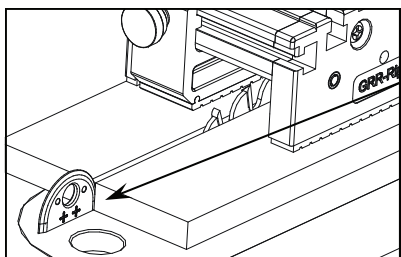

Step 8
 MJ Splitter is ready for use with or without the GRR-Ripper®.
 To remove, insert a screwdriver through the hole and pull straight upward with slight thumb pressure on the top center of the splitter (See the picture to the left).

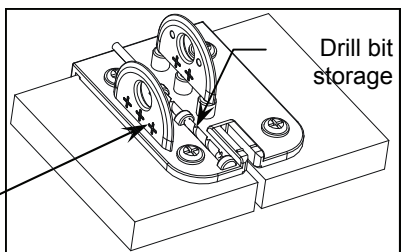
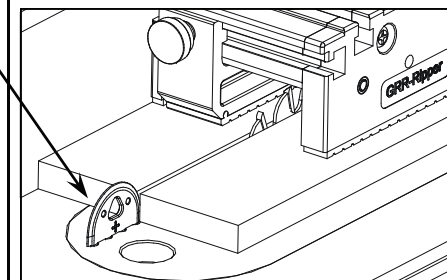

Step 9
 Store both MJ Splitters and the drill bit in the Drill Guide (drill through the first two tabs at the drill bit storage channel). Shorten the MDF Setup Board for easy storage as shown on left. The cut away portion of the Setup Board can be used as a puller with a finger-pressure squeeze from both sides to remove the MJ Splitter from the mounting holes. Alternatively, drill a through hole on the Setup Board to hang as shown on the right.

Note: Once the fence is moved, it is unlikely to have the fence returned to the exact same location as the previous installation, therefore, a new Setup board should be used with every new installation.

Drill through MDF for splitter storage. SP-0125 Green model only.

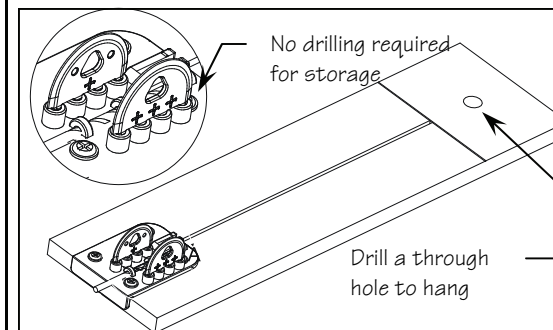

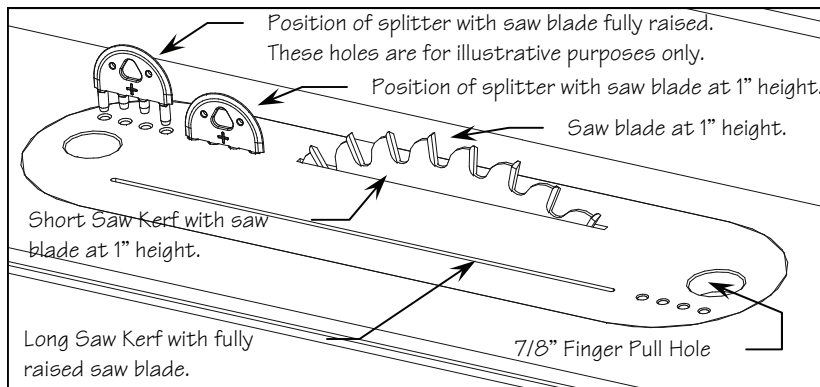

Double Kerf Bonus Trick: Some table saws allow you to rotate the ZCI from end to end. The MJ Splitter brings valuable advantages to this feature. Now you can create two kerfs on the same plastic or wood ZCI as shown in the drawing on the left. One kerf is created with saw blade fully raised for thick stock, and the other with the shorter kerf is for use with the saw blade at 1" height for 3/4" stock. In this case, install the MJ Splitter about

1 1/2" closer to the saw blade. In order to properly install the MJ Splitter for the 1" height kerf, in Step 3, draw a line on the Setup Board that is 1/2" from the Drill Guide and align the first carbide tooth flush with top of the Setup Board and the 1/2" line, and then proceed to Step 4. Similarly, you can also create one kerf for a 1/8" saw blade and the other for a thin kerf blade. **Only use the MJ Splitter designated for the thickness of your saw blades!** Make sure the ZCI has a snug fit in the opening prior to installation. There is also a handy trick for easily creating the kerf on the ZCI shown in the GRR-Ripper® DVD (sold separately).

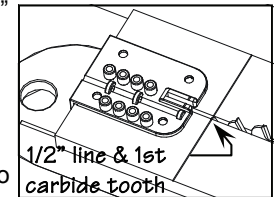

Important: Micro Jig products are designed to increase both safety and accuracy in woodworking. A unique feature of the MJ Splitter is that it also serves as a warning device when wood is not suitable for cutting on the table saw, or when your technique is inherently unsafe. Cutting wood with internal stress on the table saw can often lead to bodily injury as well as damage to equipment regardless of the type of safety devices in use. While closing or twisting behind the saw blade, wood with a great amount of internal stress may grab both sides of the MJ Splitter and pull it out of its mounting holes. **This is a design feature that we believe is a safer alternative.** Unsafe cutting technique can also pull the MJ Splitter from the ZCI, e.g., improper feeding with no downward pressure can cause the wood to lift off the table saw surface, and excessive feeding pressure from the off-cut side toward the fence can cause the wood to pinch the MJ Splitter. Although the MJ Splitter will act as a "kerf keeper" if it is pulled out of its mounting holes during a cutting operation – **you must consider this event a warning signal!** Turn off the table saw immediately to avoid personal injury and damage to equipment due to uncontrollable wood movement, and take the appropriate corrective action before proceeding. The use of the standard kerf green MJ Splitter (SP-0125) with a Thin Kerf blade may also cause the MJ Splitter to pop out. Using a Thin Kerf Yellow MJ Splitter (SP-0100TK) with a 1/8" saw blade may leave a gap, which will lessen its effectiveness. Be sure to **choose the MJ Splitter for the thickness of your saw blade in present use!**